

Standard Test Method

Evaluation of Pipeline and Pressure Vessel Steels for Resistance to Hydrogen-Induced Cracking

This NACE International standard represents a consensus of those individual members who have reviewed this document, its scope, and provisions. Its acceptance does not in any respect preclude anyone, whether he has adopted the standard or not, from manufacturing, marketing, purchasing, or using products, processes, or procedures not in conformance with this standard. Nothing contained in this NACE International standard is to be construed as granting any right, by implication or otherwise, to manufacture, sell, or use in connection with any method, apparatus, or product covered by Letters Patent, or as indemnifying or protecting anyone against liability for infringement of Letters Patent. This standard represents minimum requirements and should in no way be interpreted as a restriction on the use of better procedures or materials. Neither is this standard intended to apply in all cases relating to the subject. Unpredictable circumstances may negate the usefulness of this standard in specific instances. NACE International assumes no responsibility for the interpretation or use of this standard by other parties and accepts responsibility for only those official NACE International interpretations issued by NACE International in accordance with its governing procedures and policies which preclude the issuance of interpretations by individual volunteers.

Users of this NACE International standard are responsible for reviewing appropriate health, safety, environmental, and regulatory documents and for determining their applicability in relation to this standard prior to its use. This NACE International standard may not necessarily address all potential health and safety problems or environmental hazards associated with the use of materials, equipment, and/or operations detailed or referred to within this standard. Users of this NACE International standard are also responsible for establishing appropriate health, safety, and environmental protection practices, in consultation with appropriate regulatory authorities if necessary, to achieve compliance with any existing applicable regulatory requirements prior to the use of this standard.

CAUTIONARY NOTICE: NACE International standards are subject to periodic review, and may be revised or withdrawn at any time without prior notice. NACE International requires that action be taken to reaffirm, revise, or withdraw this standard no later than five years from the date of initial publication. The user is cautioned to obtain the latest edition. Purchasers of NACE International standards may receive current information on all standards and other NACE International publications by contacting the NACE International Membership Services Department, 1440 South Creek Drive, Houston, Texas 77084-4906 (telephone +1 281/228-6200).

Revised 2003-01-17
Revised 1996-Mar-30
Reaffirmed 1987-Mar
Approved 1984-Feb
NACE International
1440 South Creek Drive
Houston, Texas 77084-4906
+1 281/228-6200

ISBN 1-57590-163-3
© 2003, NACE International

Foreword

Absorption of hydrogen generated by corrosion of steel in a wet hydrogen sulfide (H₂S) environment can have several effects that depend on the properties of the steel, the characteristics of the environment, and other variables. One adverse effect observed in pipeline and pressure vessel steels is the development of cracks along the rolling direction of the steel. Cracks on one plane tend to link up with the cracks on adjacent planes to form steps across the thickness. The cracks can reduce the effective wall thickness until the pipe or pressure vessel becomes overstressed and ruptures. Cracking is sometimes accompanied by surface blistering. Several service failures attributed to such cracking have been reported.^{1,2}

The terms *stepwise cracking* (SWC), *hydrogen pressure cracking*, *blister cracking*, and *hydrogen-induced stepwise cracking* have been used in the past to describe cracking of this type in pipeline and pressure vessel steels, but are now considered obsolete. The term *hydrogen-induced cracking* (HIC) has been widely used for describing cracking of this type, and has been adopted by NACE International. Therefore, it is used throughout this standard test method.

HIC is related to hydrogen blistering, which has been recognized since the 1940s as a problem in vessels handling sour products.³ It was not until much later, however, that HIC gained wide recognition as a potential problem in pipelines. As a result of pipeline failures experienced by two companies in the early 1970s, several companies began investigating the cracking and publishing results of tests on various steels. Many investigators found, however, that they could not reproduce published test results. It was eventually determined that lack of reproducibility resulted largely from differences in test procedures. Consequently, NACE Unit Committee T-1F on Metallurgy of Oilfield Equipment established Task Group T-1F-20 to study the problem and prepare a standard test method.

This standard was originally prepared in 1984 to provide a standard set of test conditions for consistent evaluation of pipeline steels and for comparison of test results from different laboratories. More recently, the concern for HIC damage has turned to plate steels for pressure vessels. Requirements for plate steels have included tests for resistance to HIC using this standard. Therefore, the scope of this standard was revised to include the testing of pressure vessel plate steels.

Test conditions are not designed to simulate any particular pipeline or process operation. The test is intended to evaluate resistance to HIC only, and not other adverse effects of sour environments such as sulfide stress cracking, pitting, or weight loss from corrosion.

This test may be used for many purposes, and the applications of the results are beyond the scope of this standard. Those who use the test should be aware that in some cases test results can be influenced by variations in properties among different locations in a single length of line pipe or plate, as well as by variations within a heat of steel. When the test is used as a basis for purchasing, the number and location of test specimens must be carefully considered.⁴ This standard is intended for end users, manufacturers, fabricators, and testing laboratories.

This standard was revised by Task Group T-1F-20 in 1996, and again in 2003 by Task Group 082 (formerly T-1F-20) on Stepwise Cracking of Pipeline Steels, and is published by NACE under the auspices of Specific Technology Group 32 on Oil and Gas Production—Metallurgy (formerly Unit Committee T-1F on Metallurgy of Oilfield Equipment).

In NACE standards, the terms *shall*, *must*, *should*, and *may* are used in accordance with the definitions of these terms in the *NACE Publications Style Manual*, 4th ed., Paragraph 7.4.1.9. *Shall* and *must* are used to state mandatory requirements. The term *should* is used to state something good and is recommended but is not mandatory. The term *may* is used to state something considered optional.

**NACE International
Standard
Test Method**

**Evaluation of Pipeline and Pressure Vessel Steels for
Resistance to Hydrogen-Induced Cracking**

Contents

1. General.....	1
2. Reagents.....	1
3. Testing Apparatus.....	1
4. Test Specimens—Pipeline Steels.....	1
5. Test Specimens—Pressure Vessel Plate.....	5
6. Test Procedure.....	7
7. Evaluation of Test Specimens.....	8
8. Reporting Test Results.....	9
References.....	9
Appendix A—Safety Considerations in Handling H ₂ S Toxicity.....	10
Appendix B—Explanatory Notes on Test Method.....	11
Appendix C—Determination of H ₂ S Concentration in Test Solution by Iodometric Titration.....	11
Figure 1—Schematic Diagram of Typical Test Assembly.....	2
Figure 2—Seamless Pipe and Parent Metal of Longitudinally Welded Pipe.....	2
Figure 3—Weld Area of Longitudinally Welded Pipe.....	3
Figure 4—Weld Area of ERW Pipe.....	4
Figure 5—Parent Metal of Spiral-Welded Pipe.....	4
Figure 6—Weld Area of Spiral-Welded Pipe.....	5
Figure 7—Test Specimen Location for Plates Up to 30 mm Thick, Inclusive.....	6
Figure 8—Test Specimen Location for Plates Over 30 mm to 88 mm, Inclusive.....	6
Figure 9—Test Specimen Location for Plates Over 88 mm.....	7
Figure 10—Orientation of Test Specimens in the Test Vessel.....	7
Figure 11—Test Specimen and Crack Dimensions to Be Used In Calculating CSR, CLR, and CTR.....	9

Section 1: General

1.1 This standard establishes a test method for evaluating the resistance of pipeline and pressure vessel plate steels to HIC caused by hydrogen absorption from aqueous sulfide corrosion.

1.1.1 Special procedures or requirements for testing small-diameter (nominal pipe size [NPS] 2 through 6), thin-wall (up to 6-mm wall thickness), electric-resistance welded (ERW) and seamless line pipe are included. These small-diameter, thin-wall materials shall be tested in the same manner as other line pipe except as otherwise stated in this standard.

1.2 The test method consists of exposing unstressed test specimens to one of the two standard test solutions—either Solution A, a sodium chloride, acetic acid (NaCl, CH₃COOH) solution saturated with H₂S at ambient temperature and pressure, or Solution B, a synthetic

seawater solution saturated with H₂S at ambient temperature and pressure. After a specified time the test specimens shall be removed and evaluated.

1.3 The test method is not intended to duplicate service conditions. It is intended to provide reproducible test environments capable of distinguishing the susceptibility of different steel samples to HIC in a relatively short time. NOTE: The length of the test may not be sufficient to develop maximum cracking in any given steel but has been found to be adequate for the purpose of this test.

1.4 This standard does not include acceptance or rejection criteria. The methods used for determining acceptance and rejection, for comparing different steels, for screening of steels, or for other purposes are beyond the scope of this standard.

Section 2: Reagents

2.1 The reagents for Solution A shall be nitrogen gas for purging, H₂S gas, NaCl, CH₃COOH, and distilled or deionized water. The reagents for Solution B shall be nitrogen gas for purging, H₂S gas, and synthetic seawater. NOTE: H₂S IS HIGHLY TOXIC AND MUST BE HANDLED WITH CAUTION (see Appendix A).

2.2 The NaCl and CH₃COOH shall be reagent grade chemicals.

2.3 The gases shall be reagent grade or chemically pure gases and the water shall be distilled or deionized (see Appendix B).

2.4 The synthetic seawater shall be prepared in accordance with ASTM⁽¹⁾ Standard D 1141,⁵ Stock Solutions No. 1 and No. 2 (without heavy metal ions).

Section 3: Testing Apparatus

3.1 The test may be performed in any convenient airtight vessel large enough to contain the test specimens with provisions for purging and introduction of H₂S. None of the

materials involved in the test set-up shall contaminate or react with the test environment. Figure 1 is a schematic diagram of a typical test assembly.

Section 4: Test Specimens—Pipeline Steels

4.1 Size

4.1.1 Each test specimen shall be 100 ±1 mm long by 20 ±1 mm wide.

4.1.2 The test specimen thickness shall be the full wall thickness of the pipe up to a maximum of 30 mm. For wall thickness greater than 30 mm, the test specimen thickness shall be either the full wall thickness of the

pipe or limited to a maximum thickness of 30 mm as described in Section 5. A maximum of 1 mm may be removed from each of the surfaces (i.e., internal and external). Test specimen blanks shall not be flattened.

4.1.3 For small-diameter, thin-wall ERW and seamless line pipe, the test specimen thickness must be at least 80% of the full wall thickness of the pipe. In such cases, curved test specimens cut from the line pipe

⁽¹⁾ ASTM International (ASTM), 100 Barr Harbor Dr., West Conshohocken, PA 19428-2959.

TM0284-2003

shall be tested; test specimen blanks shall not be flattened.

4.2 Number, Location, and Orientation

4.2.1 Three test specimens shall be taken from each test pipe.

4.2.2 For welded pipe, the test specimens shall be taken from the weld, 90 degrees from the weld, and 180 degrees from the weld. For seamless pipe, the test specimens shall be taken 120 degrees apart around the circumference.

4.2.3 Test specimens shall be taken from the pipe with the longitudinal axis of the test specimens:

- (a) parallel to the longitudinal axis of the pipe for seamless pipe and the parent metal of longitudinally welded pipe.
- (b) parallel to the weld for the parent metal of spiral-welded pipe.
- (c) perpendicular to the weld for the weld area of welded pipe.
- (d) parallel to the weld for the weld area of ERW line pipe. The weld shall be approximately on the center line of the test specimen.

Figures 2 through 6 show the orientation of test specimens and where they shall be sectioned and examined after exposure.

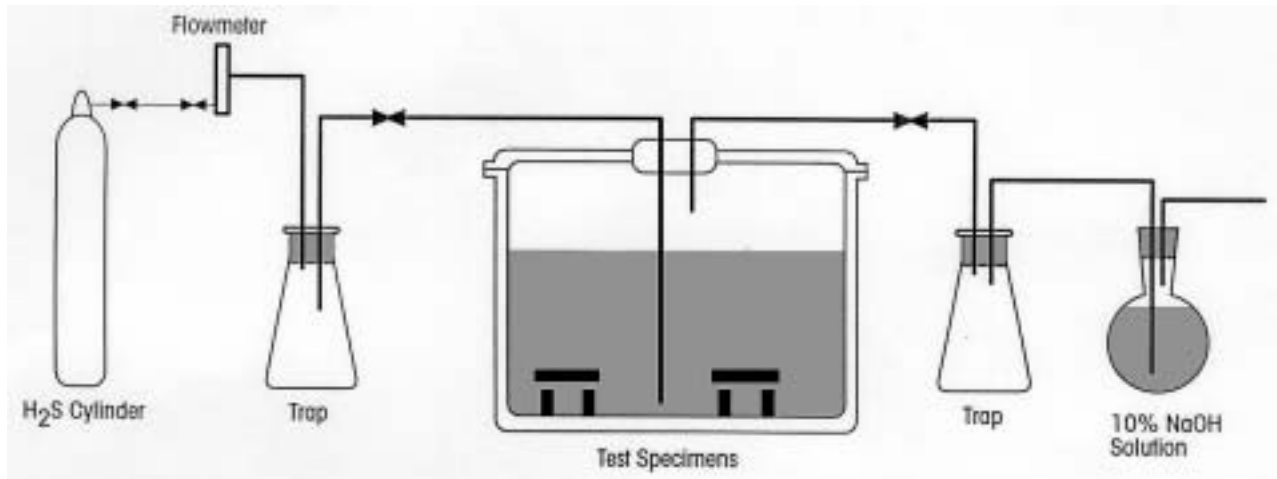

FIGURE 1
Schematic diagram of typical test assembly

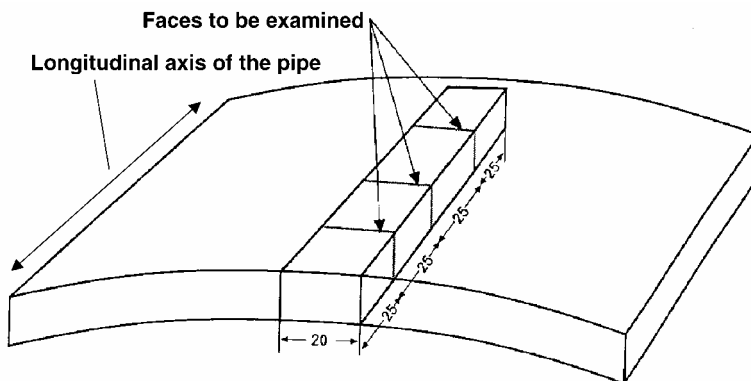

FIGURE 2
Seamless pipe and parent metal of longitudinally welded pipe
(all dimensions in mm)

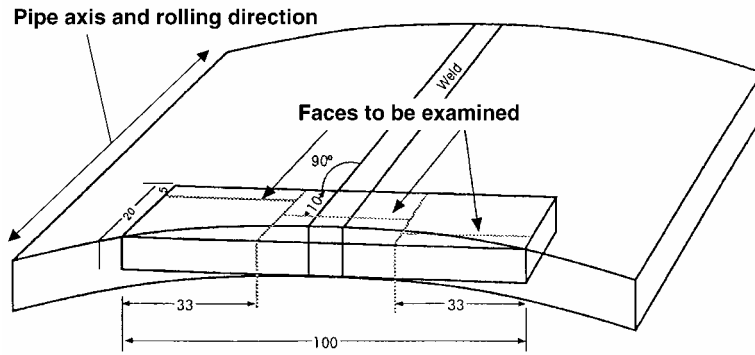
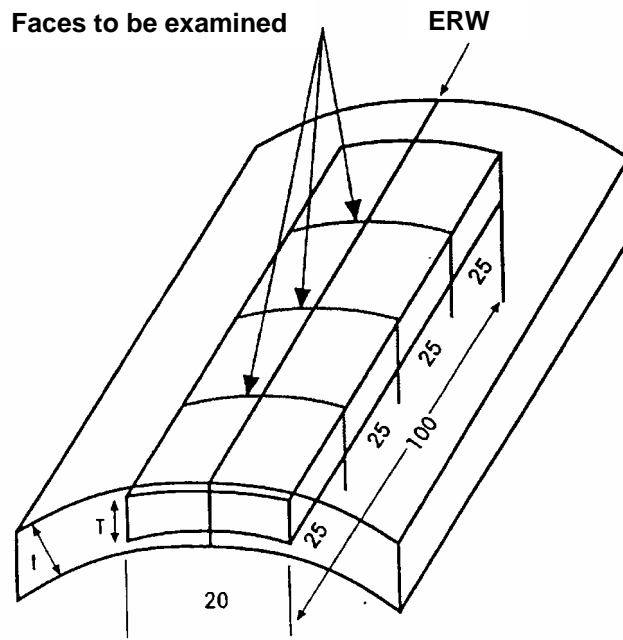

FIGURE 3
Weld area of longitudinally welded pipe
(all dimensions in mm)



a: small diameter, thin wall

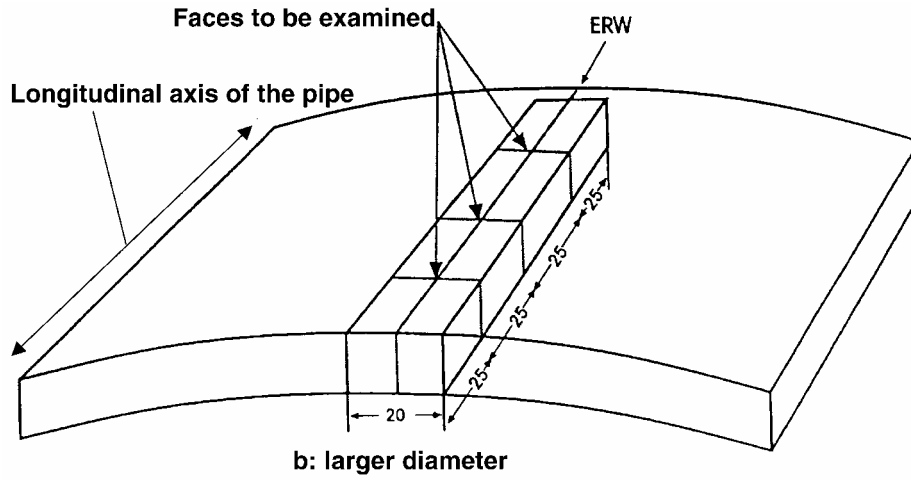

FIGURE 4
Weld area of ERW pipe
(all dimensions in mm)

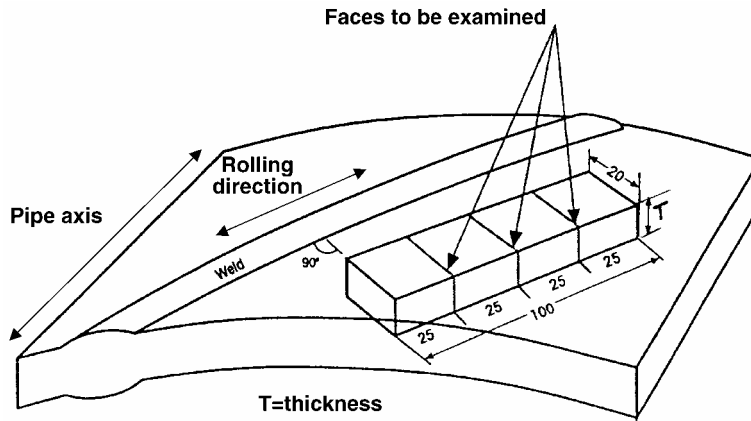

FIGURE 5
Parent metal of spiral-welded pipe
(all dimensions in mm)

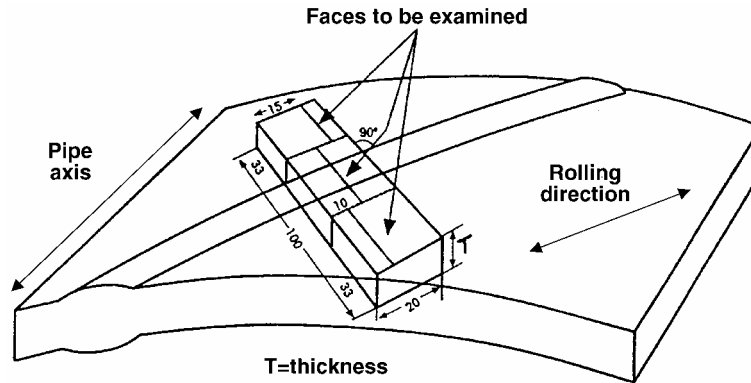

FIGURE 6
Weld area of spiral-welded pipe
(all dimensions in mm)

4.3 Preparation

4.3.1 Blanks for test specimens may be removed by any convenient method. If a blank is torch-cut, the heat-affected zone of the torch-cut surface shall be completely removed by grinding, sawing, or machining.

4.3.2 The four cut edge surfaces of each test specimen shall be ground either wet or dry and finished with 320 grit paper.

4.3.3 Coating of the cut edge surfaces is not allowed; all six surfaces shall be exposed to the test solution.

4.3.4 Small-diameter, thin-wall ERW and seamless line pipe test specimens shall have all mill scale removed from the internal and external surfaces. Either machining and/or grinding (wet or dry) shall result in a bare metal surface with a finish equivalent to 320 grit. For machining, the last two passes shall be such that a maximum of 0.05 mm of material is removed.

4.4 Cleaning and Storing

4.4.1 Prior to testing, the test specimens shall be degreased with 1,1,1-trichloroethane or similar degreasing solution and rinsed with an appropriate solvent, such as acetone. The adequacy of the degreasing method shall be determined by the atomizer test in accordance with ASTM Standard F 21⁶ or other equivalent method. The method used shall be reported.

4.4.2 Test specimens may be stored in a desiccator no longer than 24 hours after degreasing. If stored longer, they shall be degreased again before exposure.

4.4.3 After exposure, each test specimen shall be cleaned to remove scale and deposits. Test specimens may be cleaned with detergent and a wire brush or may be lightly sandblasted. Test specimens must not be cleaned with acid or by any other means that might promote hydrogen absorption.

Section 5: Test Specimens—Pressure Vessel Plate

5.1 Size

5.1.1 Each test specimen shall be 100 ± 1 mm long by 20 ± 1 mm wide.

5.1.2 A maximum of 1 mm may be removed from the rolled surfaces. Test specimen blanks shall not be flattened.

5.1.3 The test specimen thickness shall be the full thickness of the plate, up to a maximum of 30 mm. For plates thicker than 30 mm, the test specimens shall be staggered as indicated in Paragraphs 5.2.3 and 5.2.4.

5.2 Location, Orientation, and Number

5.2.1 The test specimen location for pressure vessel plate steel shall be at one end, mid-width of the plate, with the longitudinal axis of the test specimen parallel to the principal rolling direction of the plate.

5.2.2 For plates up to 30 mm thick, inclusive, three test specimens shall be taken as shown in Figure 7.

5.2.3 For plates over 30 mm to 88 mm thick, inclusive, three test specimens, each 30 mm thick, located near both surfaces and at the center line shall be taken to provide for testing of the full plate thickness, as shown in Figure 8. The overlap shall be determined by the actual plate thickness.

TM0284-2003

5.2.4 For plates over 88 mm thick, five or more test specimens (there must be an uneven number), each 30 mm thick, shall be taken as shown in Figure 9. The

minimum overlap shall be 1 mm between adjacent test specimens.

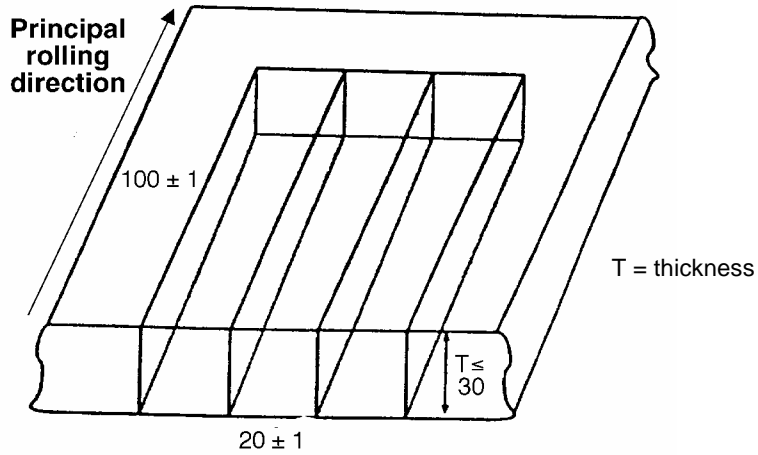

FIGURE 7
Test specimen location for plates up to 30 mm thick, inclusive
(all dimensions in mm)

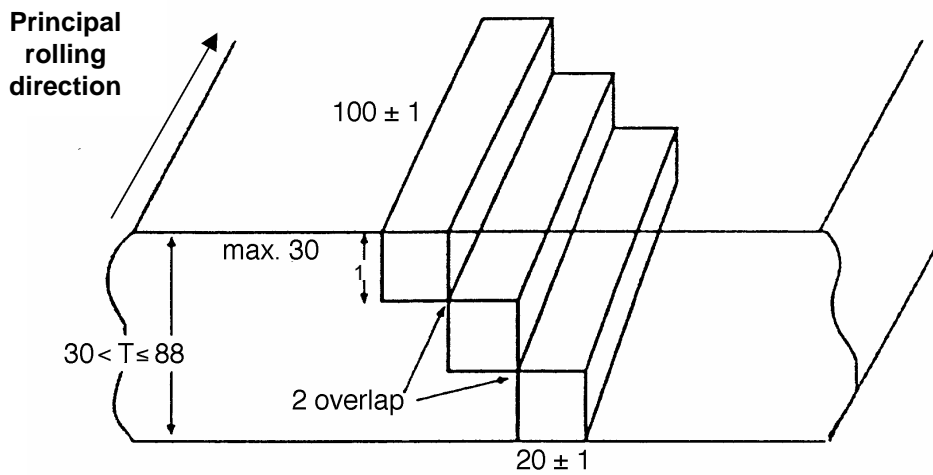

FIGURE 8
Test specimen location for plates over 30 mm to 88 mm, inclusive
(all dimensions in mm)

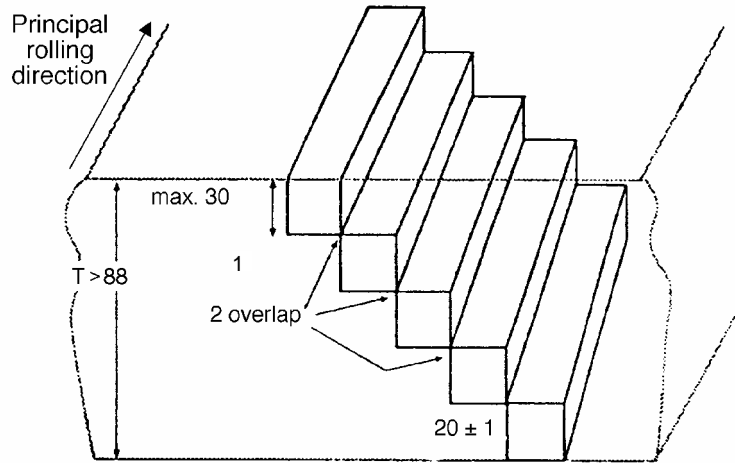

FIGURE 9
Test specimen location for plates over 88 mm (all dimensions in mm)

5.3 Preparation

5.3.1 The preparation of pressure vessel plate test specimens shall be the same as specified for pipeline steels in Paragraph 4.3.

5.4 Cleaning and Storing

5.4.1 The cleaning and storing of pressure vessel plate test specimens shall be the same as specified for pipeline steels in Paragraph 4.4.

Section 6: Test Procedure

6.1 Test Specimen Exposure

6.1.1 Test specimens shall be placed in the test vessel with the wide faces vertical and separated from the

vessel and other test specimens by glass or other nonmetallic rods with a minimum diameter of 6 mm. The longitudinal axis of the test specimens may be either vertical or horizontal (see Figure 10).

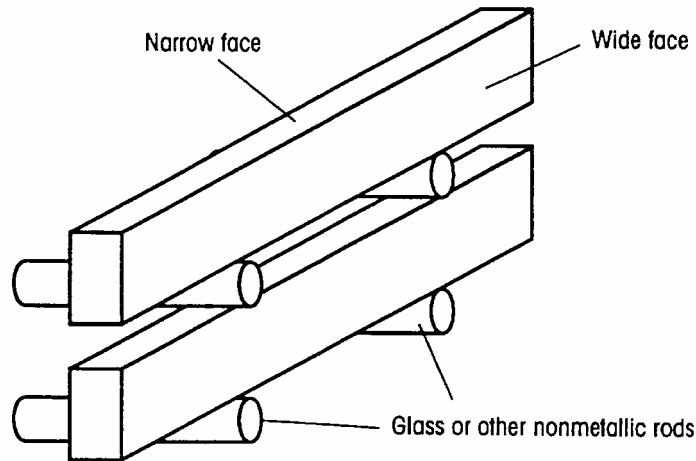

FIGURE 10
Orientation of test specimens in the test vessel

6.1.2 The ratio of the volume of test solution to the total surface area of the test specimens shall be a

minimum of 3 mL per cm². As long as the specified ratio of volume of test solution to test specimen surface

area is maintained, as many test specimens as will fit in the test vessel fully submerged and without touching may be exposed at one time.

6.1.3 If Solution A is used, the test solution shall be prepared in a separate sealed vessel that is purged with nitrogen for at least one hour at a rate of 100 mL per minute per liter of test solution prior to transferring the test solution to the test vessel. The test solution shall consist of 5.0 weight % NaCl and 0.50 weight % CH₃COOH in distilled or deionized water, i.e., 50.0 g of NaCl and 5.00 g of CH₃COOH shall be dissolved in each 945 g of distilled or deionized water. The initial pH shall be 2.7 ±0.1. All reagents added to the test solution shall be measured to ±1.0% of the quantities specified.

6.1.4 If Solution B is used, the test vessel shall be filled with synthetic seawater (see Paragraph 2.4) and the pH of the test solution measured and recorded. The pH of the synthetic seawater shall be within the range of 8.1 to 8.3 for the test to be valid. The test vessel shall then be sealed prior to purging and saturating with H₂S.

6.2 Purging and Introduction of H₂S

6.2.1 The nitrogen purge gas and H₂S gas shall be introduced near the bottom of the test vessel.

6.2.2 The sealed test vessel shall be purged of air with nitrogen for at least one hour. Purging shall begin immediately after the test vessel is filled and shall be done at a rate of at least 100 mL per minute, per liter of test solution.

6.2.3 After purging, H₂S gas shall be bubbled through the test solution. The rate of bubbling shall be at least 200 mL per minute, per liter of test solution for the first 60 minutes; thereafter, a positive pressure of H₂S gas must be maintained. The concentration of H₂S in the test solution shall be measured by iodometric titration and shall be a minimum of 2,300 ppm. An accepted iodometric titration procedure is detailed in Appendix C.

6.3 pH Measurement

6.3.1 pH at Start of Test—If solution A is used, the pH at the start of the test shall be measured immediately after H₂S saturation and shall not exceed 3.3. If Solution B is used, the pH shall be measured immediately after H₂S saturation and shall be within the range of 4.8 to 5.4.

6.3.2 pH at End of Test—At the end of the test, the pH of the test solution shall be measured. For Solution A, the pH shall not exceed 4.0 for the test to be valid. For Solution B, the pH shall be within the range of 4.8 to 5.4 for the test to be valid.

6.4 Test Duration

6.4.1 The test duration shall be 96 hours. The test time shall begin immediately upon completion of the initial 60-minute H₂S introduction period (see Paragraph 6.2.3).

6.5 Test Temperature

6.5.1 The temperature of the test solution shall be 25 ±3°C (77 ±5°F).

Section 7: Evaluation of Test Specimens

7.1 After testing, each pipeline test specimen shall be sectioned as shown in Figures 2 through 6 and the indicated surfaces examined. After testing, each pressure vessel plate test specimen shall be sectioned as shown in Figure 2 and the indicated surfaces examined.

7.2 Each section shall be polished metallographically and etched, if necessary, so that cracks can be distinguished from small inclusions, laminations, scratches, or other discontinuities. Only a light etch shall be used; a heavy etch may obscure small cracks. It is important to use a metallographic preparation method that does not smear the metal surfaces such that significant cracks may become invisible. Therefore, all faces to be examined shall be subjected to either wet magnetic particle testing or macroetching prior to final metallographic polishing. Alternatively, a preparation procedure that is described in detail and has proved to result in clearly visible cracks (if present) after final polishing may be used.

7.3 Cracks shall be measured as illustrated in Figure 11. In measuring crack length and thickness, cracks separated by less than 0.5 mm shall be considered a single crack. All identifiable cracks visible at magnifications up to 100X shall be included in the calculation, except those that lie entirely within 1.0 mm of the internal or external surface of the test specimen. (It may be necessary to examine some sections at higher magnifications to distinguish between small cracks, inclusions, pits on the side surfaces, or other discontinuities.)

7.4 The ratios shown in Equations (1), (2), and (3) shall be calculated and reported for each section and the average for each test specimen.

$$\text{Crack Sensivity Ratio, CSR} = \frac{\sum (a \times b)}{(W \times T)} \times 100\% \quad (1)$$

$$\text{Crack Length Ratio, CLR} = \frac{\sum a}{W} \times 100\% \quad (2)$$

Crack Thickness Ratio, CTR = $\frac{\sum b}{T} \times 100\%$ (3)

W = section width
T = test specimen thickness

Where: a = crack length
b = crack thickness

Note: In the past CSR has been calculated by some investigators as $(\sum a \times \sum b)/(W \times T)$, which is simply the product of CLR x CTR, i.e., $\sum a/W \times \sum b/T$; it does not give the same value as $\sum (a \times b)/(W \times T)$.

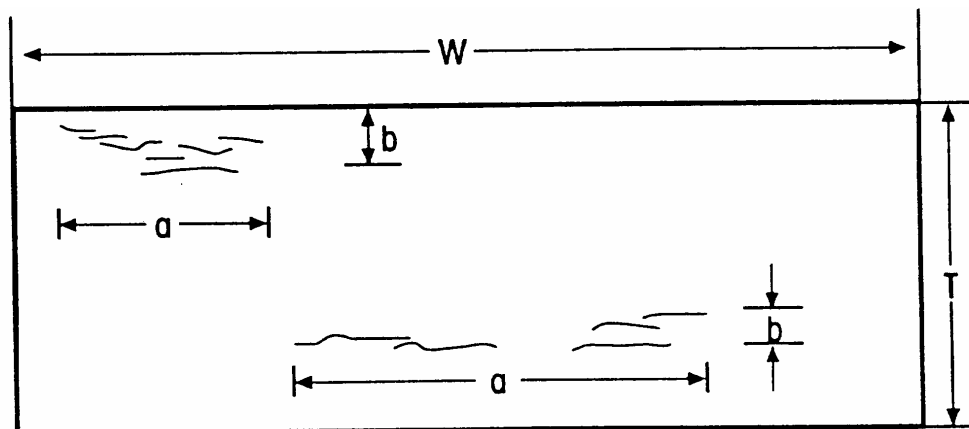

FIGURE 11
Test specimen and crack dimensions to be used in calculating CSR, CLR, and CTR

Section 8: Reporting Test Results

8.1 The type, grade, and manufacturing method of the pipe or plate shall be reported (e.g., API⁽²⁾ 5L,⁷ grade X52, seamless; ASTM A 53,⁸ grade B, electric-resistance welded; ASTM A 516,⁹ grade 70, etc.). Manufacturer, chemical composition, heat treatment, mechanical properties, and plate processing data shall be included, if available.

8.2 The following shall be reported:

- (a) Method of testing for adequacy of test specimen degreasing
- (b) Test solution used (Solution A or Solution B—if Solution B, indicate Stock Solution No. 1 and No. 2 for synthetic seawater)

(c) pH of the test solution before introduction of H₂S—specified in Paragraphs 6.1.3 and 6.1.4

8.3 Any test condition and procedure not in accordance with this standard shall be reported.

8.4 The individual CSR, CLR, and CTR shall be reported for each of the three sections from each test specimen, and the average CSR, CLR, and CTR shall be reported for each test specimen.

8.5 For small-diameter, thin-wall ERW and seamless line pipe, the actual wall thickness as well as the test specimen thickness as a percentage of the pipe wall thickness shall be reported.

References

1. F. Parades, W.W. Mize, "Unusual Pipeline Failures Traced to Hydrogen Blisters," Oil and Gas Journal 53, 33 (1954): pp. 99-101.
2. E.M. Moore, J.J. Warga, "Factors Influencing the Hydrogen Cracking Sensitivity of Pipeline Steels," Materials Performance 15, 6 (1976): pp. 17-23.

⁽²⁾ American Petroleum Institute (API), 1220 L St NW, Washington, DC 20005.

TM0284-2003

3. M.H. Bartz, C.E. Rawlins, "Effects of Hydrogen Generated by Corrosion of Steel," *Corrosion* 4, 5 (1948): pp. 187-206.
4. E.M. Moore, D.A. Hansen, "Specifying Linepipe Suitable for Safe Operation in Sour, Wet Service," Paper No. 81 PET-1, presented at the American Society of Mechanical Engineers Energy Sources Technology Conference, Houston, TX, January 18-22, 1981.
5. ASTM Standard D 1141 (latest revision), "Standard Specification for Substitute Ocean Water" (West Conshohocken, PA: ASTM).
6. ASTM Standard F 21 (latest revision), "Standard Test Method for Hydrophobic Surface Films by the Atomizer Test" (West Conshohocken, PA: ASTM).
7. API Specification 5L (latest revision), "Specification for Line Pipe" (Washington, DC: API).
8. ASTM Standard A 53 (latest revision), "Standard Specification for Pipe, Steel, Black and Hot-Dipped, Zinc-Coated, Welded and Seamless" (West Conshohocken, PA: ASTM).
9. ASTM Standard A 516/A 516M (latest revision), "Standard Specification for Pressure Vessel Plates, Carbon Steel, for Moderate- and Lower-Temperature Service" (West Conshohocken, PA: ASTM).
10. OSHA⁽³⁾ Rules and Regulations, Federal Register, Vol. 37, No. 202, Part II, OSHA, Washington, DC, 1972.
11. Chemical Safety Data Sheet SD-36, Manufacturing Chemists Association, 1825 Connecticut Ave. NW, Washington, DC 20009.
12. N. Irving Sax, *Dangerous Properties of Industrial Materials* (New York, NY: Reinhold Book Corp., 1984; also American Conference of Governmental Industries Hygienists, 1969).

Appendix A—Safety Considerations in Handling H₂S Toxicity

H₂S is perhaps responsible for more industrial poisoning accidents than is any other single chemical. A number of these accidents have been fatal. H₂S must be handled with caution and any experiments using it must be planned carefully. The Occupational Safety and Health Administration (OSHA) maximum allowable concentration of H₂S in the air for an eight-hour work day is 20 parts per million (ppm), well above the level detectable by smell.¹⁰ However, the olfactory nerves can become deadened to the odor after exposure of 2 to 15 minutes, depending on concentration, so that odor is not a completely reliable alarm system.

Briefly, the following are some of the human physiological reactions to various concentrations of H₂S. Exposure to concentrations in the range of 150 to 200 ppm for prolonged periods may cause edema of the lungs. Nausea, stomach distress, belching, coughing, headache, dizziness, and blistering are symptoms of poisoning in this range of concentration. Pulmonary complications, such as pneumonia, are strong possibilities from such subacute exposure. At 500 ppm, unconsciousness may occur in less than 15 minutes, and death within 30 minutes. At concentrations above 1,000 ppm, a single inhalation may result in instantaneous unconsciousness, complete respiratory failure, cardiac arrest, and death.

Additional information on the toxicity of H₂S can be obtained from the Chemical Safety Data Sheet SD-36¹¹ and from *Dangerous Properties of Industrial Materials*.¹²

Fire and Explosion Hazards

H₂S is a flammable gas and yields poisonous sulfur dioxide (SO₂) as a combustion product. In addition, its explosive limits range from 4 to 46% in air. Appropriate precautions shall be taken to prevent these hazards from developing.

Recommended Safety Procedures During Test

All tests shall be performed in a hood with adequate ventilation to exhaust all of the H₂S. The H₂S flow rates during the test should be kept low to minimize the quantity exhausted. A 10% caustic absorbent solution for effluent gas can be used to further minimize the quantity of H₂S exhausted. This caustic solution needs periodic replenishing. Provision shall be made to prevent backflow of the caustic solution into the test vessel if the H₂S flow is interrupted. Suitable safety equipment shall be used when working with H₂S.

Because the downstream working pressure frequently rises as corrosion products, debris, etc., accumulate and interfere with regulation at low flow rates, particular attention should be given to the output pressure on the pressure regulators. Gas cylinders shall be securely fastened to prevent tipping and breaking of the cylinder head. Because H₂S is in liquid form in the cylinders, the high-pressure gauge must be checked frequently, because relatively little time elapses after the last liquid evaporates and the pressure drops from 1.7 MPa (250 psig) to atmospheric pressure. The cylinder

⁽³⁾ Occupational Safety and Health Administration (OSHA), 200 Constitution Ave. NW, Washington, DE 20210.

shall be replaced by the time it reaches 0.5 to 0.7 MPa (75 to 100 psig) because the regulator control may become erratic. Flow shall not be allowed to stop without closing a valve or disconnecting the tubing at the test vessel because the test solution continues to absorb H₂S and move upstream into the flowline, regulator, and even the cylinder.

A check valve in the line should prevent the problem if the valve works properly. However, if such an accident occurs, the remaining H₂S should be vented as rapidly and safely as possible and the manufacturer notified so that the cylinder can be given special attention.

Appendix B—Explanatory Notes on Test Method

Rationale for Reagent Purity

Water impurities of major concern are alkaline or acid buffering constituents that would alter the pH of the test solution and organic and inorganic compounds that could change the nature of the corrosion reaction. Oxidizing agents could also convert part of the H₂S to soluble products such as polysulfides and polythionic acids, which may also affect the corrosion process.

To assure free flowing characteristics, alkaline materials (magnesium carbonate [MgCO₃], sodium silica aluminate, etc.) are often added to (or are not removed from) commercial grades of NaCl and can greatly affect the pH.

Trace oxygen impurities in the purge gas would be much more critical if the nitrogen (or other inert gas) were to be continuously mixed with the H₂S in order to obtain a lower partial pressure of H₂S in the gas and, hence, a lower H₂S concentration in the test solution. Oxidation products could accumulate, resulting in changes in corrosion rate and/or hydrogen entry rate (see below).

Rationale for Exclusion of Oxygen

Obtaining and maintaining a test solution with minimum

dissolved oxygen contamination is considered very important because of significant effects noted in field and laboratory studies, such as:

1. Oxygen contamination in brines containing H₂S can increase the corrosion rate by as much as two orders of magnitude. Generally, the oxygen can also reduce hydrogen evolution and entry into the metal. Systematic studies of the parameters affecting these phenomena (as they apply to hydrogen-induced cracking) have not been reported in the literature.

2. To minimize both corrosion and hydrogen blistering, small amounts of oxygen or ammonium polysulfide are sometimes added to aqueous refinery streams in conjunction with careful pH control near 8. The effectiveness of this treatment is attributed to alteration of the corrosion product.

In the absence of sufficient data to define and clarify the effects of these phenomena on hydrogen-induced cracking, all reasonable precautions to exclude oxygen should be taken. The precautions cited in this standard minimize the effects of oxygen with little increase in cost, difficulty, or complexity.

Appendix C—Determination of H₂S Concentration in Test Solution by Iodometric Titration

This procedure details the method to be used for the determination of the of H₂S concentration in the test solution by iodometric titration.

Test Reagents/Equipment

Standard iodine solution (0.1 N⁽⁴⁾) Concentrated HCl (approx. 37 wt% HCl)

Starch solution
Standard sodium thiosulfate solution (0.1 N⁽⁴⁾)
10-mL and 25-mL pipettes
250-mL conical flask **with** stopper
100-mL beaker
25-mL burette
“Analar” grade chemicals shall be used.

⁽⁴⁾ The following standard solution concentrations and volumes should be used for H₂S-saturated solutions containing 2,300 ppm to 3,500 ppm H₂S:

0.1 N iodine solution.
0.1 N sodium thiosulphate solution
25 mL iodine solution volume
10 mL test sample volume

If the procedure is used to measure the H₂S concentration in test solutions saturated with less than 2,300 ppm H₂S, the above values may need to be adjusted to maintain accuracy.

TM0284-2003

Procedure

1. Pipette 25 mL⁽⁴⁾ of standard iodine solution (0.1 N⁽⁴⁾) into a 250-mL conical flask.
2. Acidify with approximately 5 mL of concentrated HCl.
3. Transfer approximately 50 mL of test solution from the test vessel into a clean beaker, discarding the initial 25 to 50 mL.
4. Immediately extract 10 mL of test solution from the beaker via a pipette and discard. Pipette a further 10 mL⁽⁴⁾ and transfer this sample to the conical flask.

$$\text{H}_2\text{S concentration (ppm)} = \frac{[(A - B) \times \text{Factor}]}{C} \times 17,030 \quad (\text{A1})$$

Where: A = Normality of standard iodine solution x volume used (mL)

B = Normality of standard sodium thiosulfate solution x volume used (mL)

C = Volume of sample (mL)

Factor = Standardization factor for standard iodine solution (see *Standardization* in the following Paragraphs)

Standardization

The iodine and sodium thiosulfate solutions must be standardized when they are prepared for use in this determination.

1. To standardize these solutions, pipette 25 mL of the 0.1 N iodine solution into a conical flask and titrate with the 0.1 N sodium thiosulfate solution to a clear end point.
2. Record the result.
3. Calculate the "Factor" for the H₂S concentration calculation using Equation (A2):

$$\text{Factor} = \frac{B}{A} \quad (\text{A2})$$

Where: A = Normality of iodine solution x volume used (mL)

B = Normality of sodium thiosulfate solution x volume used (mL)

5. Add approximately 2 mL of starch solution.
6. Titrate with the standard sodium thiosulfate solution (0.1 N⁽⁴⁾) until the end point changes from dark blue to pale straw.
7. Calculate the H₂S concentration (ppm) using Equation (A1):

4. If the factor is within the limits of 0.95 to 1.05, use the value of the Factor calculated in Equation (A2) in Equation (A1). These solutions are acceptable.

If the Factor is outside the set limits of 0.95 to 1.05, replace the iodine solution and repeat the standardization.

Measurement Uncertainty

The measurement uncertainty for the determination, based on a H₂S concentration of 2,500 ppm, is as follows:

$$95\% \text{ confidence interval} = \pm 4.2\%$$

Example: If a 10-mL sample mixed with 25 mL of 0.1 N iodine solution was titrated to the end point with 10 mL of 0.1 N sodium thiosulfate solution, with a Factor of 1.00, the 95% confidence interval (CI) can be calculated as shown in Equation (A3). Note that the result is $\pm 4.2\%$ of the H₂S concentration calculated in accordance with Equation (A1).

$$95\% \text{ CI} = \frac{[(2.5 - 1.0) \times 1.00]}{10} \times 17,030 \times 4.2\% \quad (\text{A3})$$

$$95\% \text{ CI} = \pm 107 \text{ ppm}$$